

INSTALLATION SPECIFICATION
DIGITAL TO FINE/COURSE XYZ SYNCHRO
MODEL, ADC-600, P/N 99100003

SKYLIGHT AVIONICS
38629 6th St. East
Palmdale, Ca. 93550
(661) 265-0497

TABLE OF CONTENTS

REFERENCE	SECTION	PAGE
(i)	OPERATING INSTRUCTIONS	1
(ii)	EQUIPMENT LIMITATIONS	1
(iii)	INSTALLATION PROCEDURES & LIMITATIONS	2
(iv)	INSTALLATION MECHANICAL DIAGRAMS	3
(v)	INSTALLATION WIRING DIAGRAMS	4
(vi)	SPECIFICATIONS	5
(vii)	MAJOR COMPONENTS	6
(viii)	ENVIRONMENTAL QUALIFICATION FORM	8

ILLUSTRATIONS

REFERENCE	TITLE	PAGE
(iv-1)	MECHANICAL INSTALLATION DRAWING	3
(v-1)	ELECTRICAL PINOUT DRAWING	4
(vii-1)	INTERCONNECT BLOCK DIAGRAM	6, 7

(i) OPERATING INSTRUCTIONS

The ADC-600 Adapter, by its design has only one operating control. The unit is designed with a discrete select input, enabling the operator to select the ADC source of the ARINC-429 input. This is accomplished with an externally mounted switch. The ADC-600 will not switch to an invalid source if valid data is available. Strapping of the installation allows choice of either Label 203 or 204 from the input to be decoded. Operating instructions of the systems that are interconnected need to be followed. The ADC-600 should appear transparent to the systems connected.

The ADC-600 Adapter, is limited to accepting (2) ARINC-429 Digital ADC's, selectable for source and converting the data as required. In normal operation the unit will monitor both inputs for valid data and present a low valid output for the status of each and a low level to signify the system being used. The unit will use the # 1 Input for data collection as the primary unless the data becomes invalid or the operator has selected the alternate input. In the event of the primary input becoming invalid the unit will switch to the secondary input if it is valid and use # 2 ADC. The unit will function in reverse order if the operator has selected the alternate input. In the event the selected input fails the unit will return to the primary input.

(ii) EQUIPMENT LIMITATIONS

The adapter is limited to converting the digital output of the new digital ADC's to ARINC-565 Fine / Coarse Synchro altitude and a Manchester encoded digital format.

The ADC-600 Adapter, as an integral component of the on board Air Data System, the update speed and accuracy is directly limited to the output driving the unit. In effect, it is a component of that system and therefore subjected to all inherent limitations of that system.

A hardware design assurance of "Level D" per RTCA DO-254 "Design Assurance Guidance for Airborne Electronic Hardware" will be applied to design verification, documentation and manufacturing.

Failure Condition Classification "Minor"

Failure Condition Description "Failure conditions that would not significantly reduce aircraft safety, and which would involve flight crew actions that are within their capabilities. Minor failure conditions may include: a slight reduction in safety margins or functional capabilities, a slight increase in flight crew workload, such as routine flight plan changes, or inconvenience to occupants."

Hardware Design Assurance Level Definition "D Hardware functions whose failure or anomalous behavior, as shown by the hardware safety assessment, would cause a failure of system function resulting in a minor failure condition for the aircraft"

The conditions and test required for TSO approval of this article are minimum performance standards. It is the responsibility of those desiring to install this article either on or within a specific type or class of aircraft to determine that the aircraft installation conditions are within the TSO standards. If not within the TSO standards, the article may be installed only if further evaluation by the applicant documents an acceptable installation and is approved by the administrator.

The ADC-600 is classified as "ON CONDITION" with no preventative maintenance required. No overhaul time limitations apply. No scheduled inspections to determine operational status are required. In the event of a failure the operator or cognizant maintenance facility shall remove the appliance and return it to Skylight Avionics for the repair or replacement.

(iii) INSTALLATION PROCEDURES

1. INTRODUCTION

This section contains information relative to the installation of the, ADC-600 Adapter, to assure satisfactory performance of the unit. (See Sections "iv" and "v" for detailed mechanical and wiring diagrams.)

2. UNPACKING AND INSPECTING EQUIPMENT

After unpacking the unit, make a visual inspection of the unit for evidence of damage incurred during shipment. If a claim for damage is to be made, save the shipping container to substantiate the claim.

3. PREINSTALLATION CHECK

Perform a continuity and power check on the wiring harness before connecting equipment.

4. POWER REQUIREMENTS

The ADC-600 operates from a standard 27.5 Volt DC aircraft power source, and 26 VAC 400 HZ reference. Provide circuit protection with an in line 1 AMP breaker on the 27.5 VDC.

5. POST INSTALLATION CHECK

There is no in-aircraft adjustment required for the ADC-600. All alignment and adjustment procedures are accomplished during bench maintenance.

6. PREFLIGHT CHECK

Following the manufactures check out procedures of the on board Instruments, verify that the Indications being driven by the ADC-600 are accurate.

(iv) INSTALLATION MECHANICAL DIAGRAMS

The ADC-600 is designed for flat mounting anywhere on board the aircraft, pressurized or non-pressurized compartments. The unit has four (4) mounting holes for number (6) size screws. (NOTE: Screws and other miscellaneous mounting hardware are NOT included with the ADC-600.

Mechanical Drawing of ADC-600

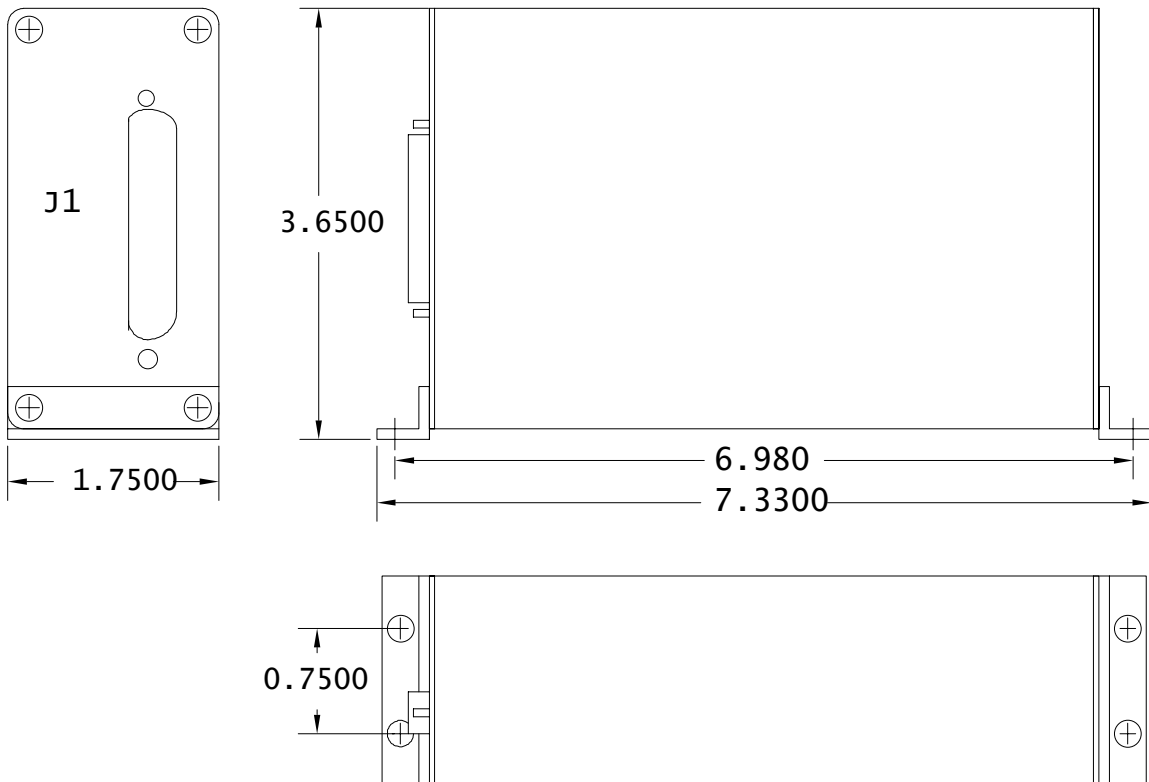

Unit Connector - DB-37P with Screw lock Retainers
Mate - DB-37S

MECHANICAL INSTALLATION DRAWING
ILLUSTRATION (iv-1)

(v) INSTALLATION WIRING DIAGRAMS

ADC-600 P/N 99100003

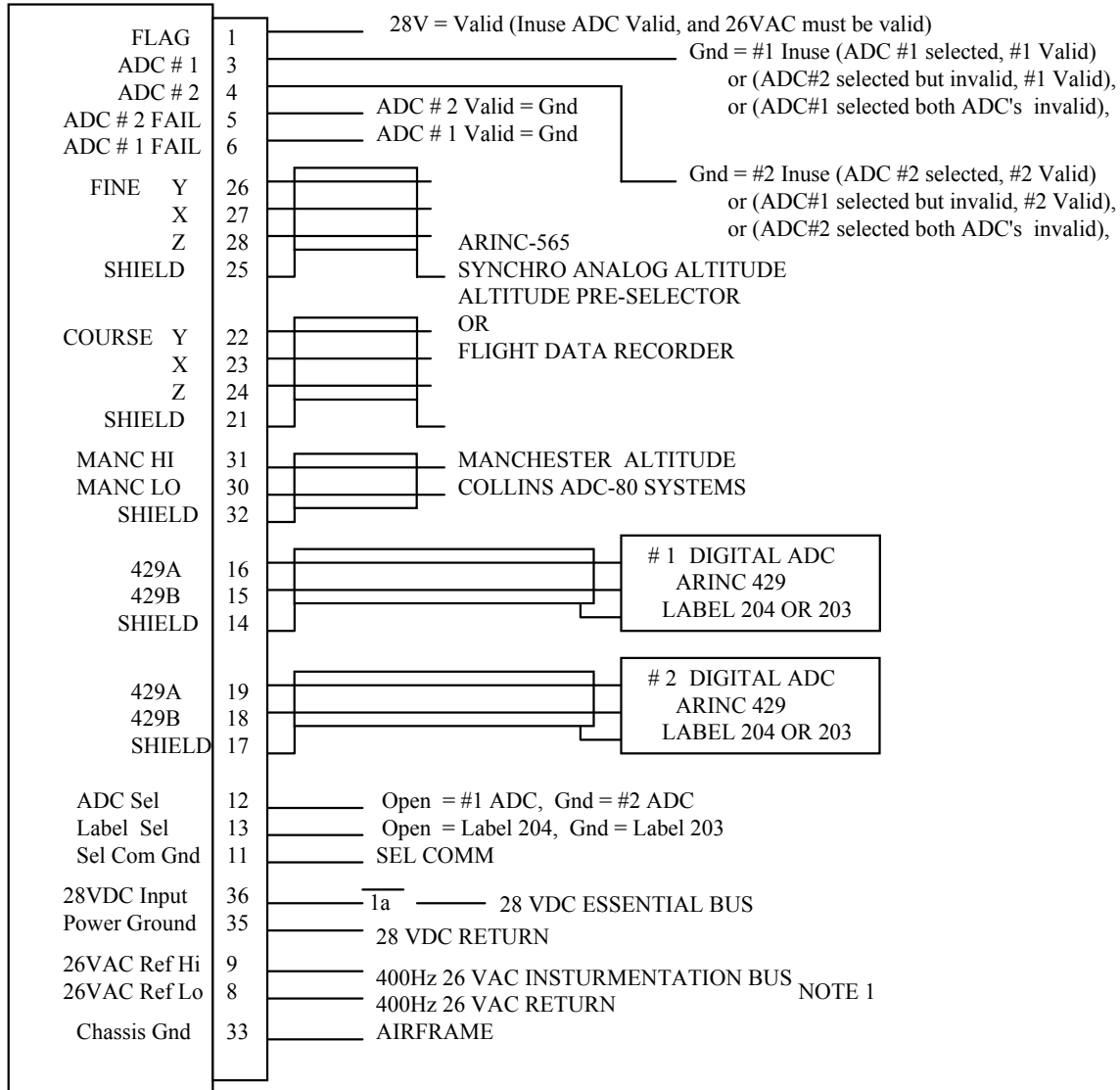

NOTE1, The 26 VAC REF is isolated and may require inverting on some installations.

ILLUSTRATION (v-1)
 ELECTRICAL PINOUT DRAWING

SKYLIGHT AVIONICS
 MODEL, ADC-600, P/N 99100003
 DOC. # 00030001, REV: 1, Date, 11/28/01

(vi.) SPECIFICATIONS

SPECIFICATION	CHARACTERISTICS
Compliance	TSO C106 (Application Package)
RTCA/DO-160D	A1D2/B/A/B/S2BM/X/X/X/X/X/Z/A/A/A/Z/VVV/M/XXC3/X/X/A
Physical Dimensions	Height 3.650" Length 7.330" Width 1.750" Weight 1.5lb
Temperature Range	Operational -55 C to +70 C Storage -55 C to +85 C
Altitude	50,000'
Power Requirements	28 VDC @ .8 AMP Peak .3 AMP Normal 26 VAC @ .1 AMP Reference only
Inputs 99100003	(2) ARINC 429 RECEIVERS, Labels 203 & 204. (2) SELECT INPUT (Discrete Ground)
99100003-1	(2) ARINC 419 RECEIVERS, Labels 203 & 204. (2) SELECT INPUT (Discrete Ground)
ARINC-565Output	FINE / COARSE SYNCHRO ALTITUDE Fine = 360 DEG / 5000 Ft. +/- .1 Degree Coarse = 360 Deg * 375 Ft. +/- .1 Degree
COLINS ADC-80 Output	MANCHESTER ENCODED ALTITUDE Label 09
Discrete output (5)	(2) VALID INDICATORS, LOW LEVEL (2) SOURCE INDICATORS, LOW LEVEL (1) SYSTEM VALID, 28 VDC
Limitations	Limited to the manufactures specifications of the digital input bus and to the specifications listed herein.

SKYLIGHT AVIONICS
 MODEL, ADC-600, P/N 99100003
 DOC. # 00030001, REV: 1, Date, 11/28/01
 (vii.) EQUIPMENT SYSTEMS MAJOR COMPONENT

Equipment Supplied:
 1ea Model ADC-600, Part Number 99100003

Equipment Required But Not Supplied:
 4ea. #6 Mounting Screws
 Connector: Standard DB37S, with Retention Screws.
 Wiring Harness Interconnect cable

540-25100-001	Altitude Pre-Selector / IDC
27050-01-01	Air Data Unit / Meggitt
28010-00-01	Encoding Altimeter / Meggitt

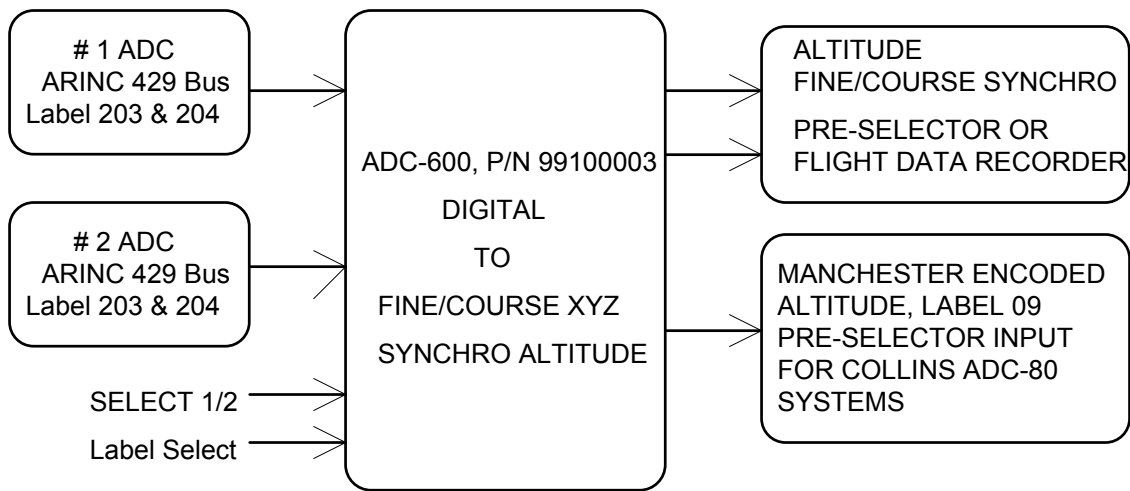

ILLUSTRATION (vii-1)

(vii.) EQUIPMENT SYSTEMS MAJOR COMPONENT

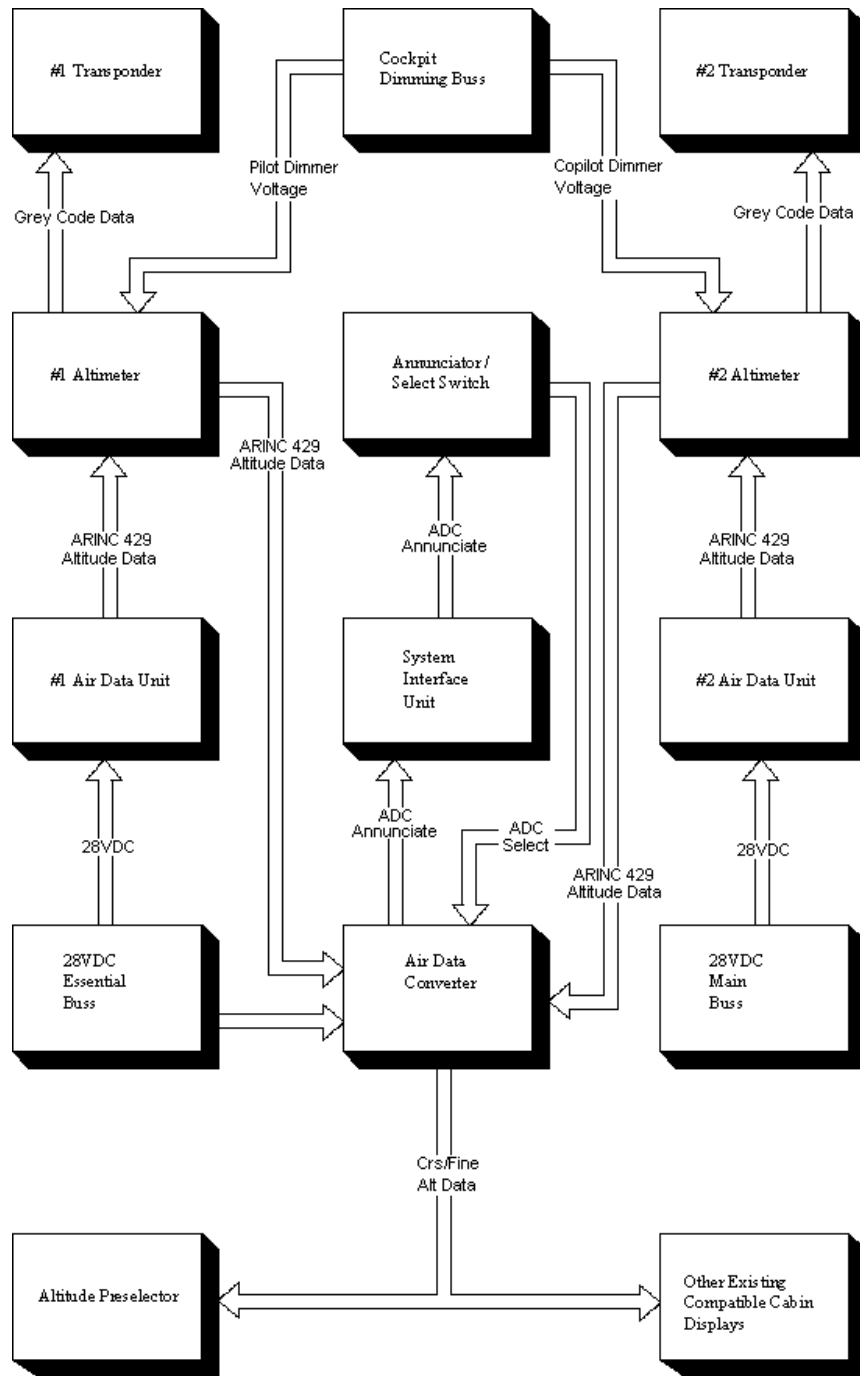

ILLUSTRATION (vii-2)
 INTERCONNECT BLOCK DIAGRAM

SKYLIGHT AVIONICS
 MODEL, ADC-600, P/N 99100003
 DOC. # 00030001, REV: 1, Date, 11/28/01

iii. ENVIRONMENTAL QUALIFICATION FORM

NOMENCLATURE: DIGITAL TO SYNCHRO ADAPTER
 TYPE / MODEL / PART NO: ADC-600, P/N 99100003
 MANUFACTURE'S SPECIFICATION;
 MANUFACTURE: SKYLIGHT AVIONICS
 ADDRESS: 38629 6th STREET EAST
 PALMDALE, CA. 93550-3717

RTCA/DO-160D, Dated July 29, 1997

Conditions	Section	Description of Conducted Tests
Temperature and Altitude	4.0	Equipment tested to Category A1/D2 Auxiliary air cooling not required.
Temperature Variation	5.0	Equipment tested to Category B
Humidity	6.0	Equipment tested to Category A
Operational Shock and Crash Safety	7.0	Equipment tested to Category B
Vibration	8.0	Equipment tested to Category S, Zone 2, Curves B & M
Explosion	9.0	Category X no test required
Waterproofness	10.0	Category X no test required
Fluids Susceptibility	11.0	Category X no test required
Sand and Dust	12.0	Category X no test required
Fungus	13.0	Category X no test required
Salt Spray	14.0	Category X no test required
Magnetic Effect	15.0	Equipment tested to Category Z
Power Input	16.0	Equipment tested to Category A
Voltage Spike	17.0	Equipment tested to Category A
Audio Frequency Susceptibility	18.0	Equipment tested to Category A
Induced Signal Susceptibility	19.0	Equipment tested to Category Z
Radio Frequency Susceptibility	20.0	Equipment tested to Category VVV
Radio Frequency Emission	21.0	Equipment tested to Category M
Lightning Induced Transient Susceptibility	22.0	Equipment tested to Category XXC3
Lightning Direct Effects	23.0	Category X no test required
Icing	24.0	Category X no test required
Electrostatic Discharge	25.0	Equipment tested to Category A

SECTIONS 4 THUR 8
 TEST REPORT #
 20702-1013365

ENVIROMENT ASSOCIATES, INC.
 9604 VARIEL AVENUE
 CHATSWORTH, CALIFORNIA 91311

SECTIONS 16 THUR 25
 TEST REPORT #
 21-231

NEMKO-EESI
 9604 VARIEL AVENUE
 CHATSWORTH, CALIFORNIA 91311