

Design Specification
Multi-function Digital Bus Reader
Model IND-5000, P/N 50-5012-(XX)

Doc # 94110041 Date 11/14/94

Skylight Avionics
38629 6th st. East
Palmdale, CA. 93550
(805) 265-0497

INDEX

Section	Title	Page
i.	Operation Instructions	2
ii.	Equipment Limitations	2
iii.	Installation Procedures	3
iv.	Installation Specifications: Physical	4
v.	Installation Specifications: Electrical	5
vi.	Specifications	6
vii.	Major Components	7
viii.	Environmental Qualification Form	8,9

Illustrations

Illustration	Title	Page
iv-1	Mechanical Drawing of IND-5000	3
v-1	IND-5000 P/N 50-5012 Pinout	4
vi-1	Interconnect Block Diagram	7

i. Operating Instructions

1. General

The IND-5000, P/N 50-5012-(XX) operation is independent of the Aircraft Navigation system to which it is interfaced, operating instructions for that system will need to be followed. The indicator should become operational upon application of aircraft avionics power and provides the following information on a one line display.

Condition	Display
No Serial Bus Input	IDLE
Altitude Invalid	----m
Altitude Valid	88888m

2. Controls

The 50-5012-XX Indicator has one control on the front panel. The "DIM" control located on the lower right and adjusts the LED display brightness. (NOTE: The panel back lighting is controlled by the aircraft instrument panel dimming).

3. Flags and Warnings

The 50-5012-XX Indicator will detect the following failures from the serial data bus:

Failure	Indication
No data Bus	Receiver "Idle"
Bad or Missing Selected Altitude	FLAG
Power or unit failure	Display Blank

ii. Equipment Limitations

The IND-5000 indicator is only a display of ARINC digital data received from other on-board flight or navigation system outputs. The update speed, accuracy, and data available for display is directly limited to the output of the system to which it is interfaced. In effect, it is a display component of that flight or navigation system and therefore subject to all inherent limitations of those systems.

The IND-5000 operates at 22 to 29.5 VDC power. It cannot be used for emergency 18 VDC operation.

iii. Installation Procedures

1. Introduction

This section contains information relative to the installation of the IND-5000 indicator to assure satisfactory performance of the unit. (See sections iv. and v. for detailed mechanical and wiring diagrams.)

2. Unpacking and Inspecting Equipment

After unpacking the IND-5000, make a visual inspection of the unit for evidence of damage incurred during shipment. If a claim for damage is to be made, save the shipping container to substantiate the claim.

3. Pre-Installation Check

The IND-5000 should be bench checked for proper system operation prior to being installed in the aircraft.

4. Power Requirements

The IND-5000 has been designed to accept from 22 to 29.5 VDC power with no special modification or wiring considerations. The IND-5000 operates from a standard +28 VDC aircraft power source. Circuit protection should be provided with an in-line 0.5 Amp breaker. Panel dimming for the unit can be either +5 or +28 VDC, depending on aircraft requirements.

5. Post-installation Check

Power: Upon application of the aircraft 28 VDC power verify the IND-5000 alphanumeric LED displays. (i.e. recv idle) System Check: After the system to which the IND-5000 has been interfaced has been verified and is operating properly, verify that each data format function is operational. Verify numerical data to other system displays where applicable (i.e. CDU, EFIS, etc.).

iv. Installation Specifications: Physical

1. Mechanical

The IND-5000 is designed for rigid mounting in a aircraft instrument panel with a standard 1/2 3ATI cutout and mounting clamp.

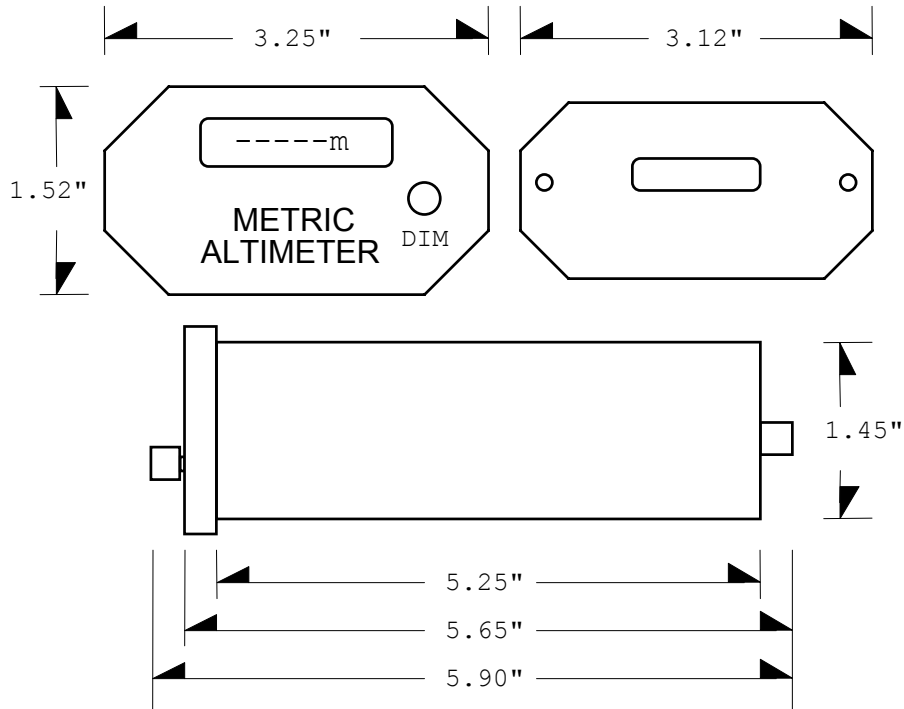

IND-5000 P/N 50-5012-(XX) Mechanical Drawing
(Illustration iv-1)

v. Installation Specifications: Electrical

1. Pinout Diagram

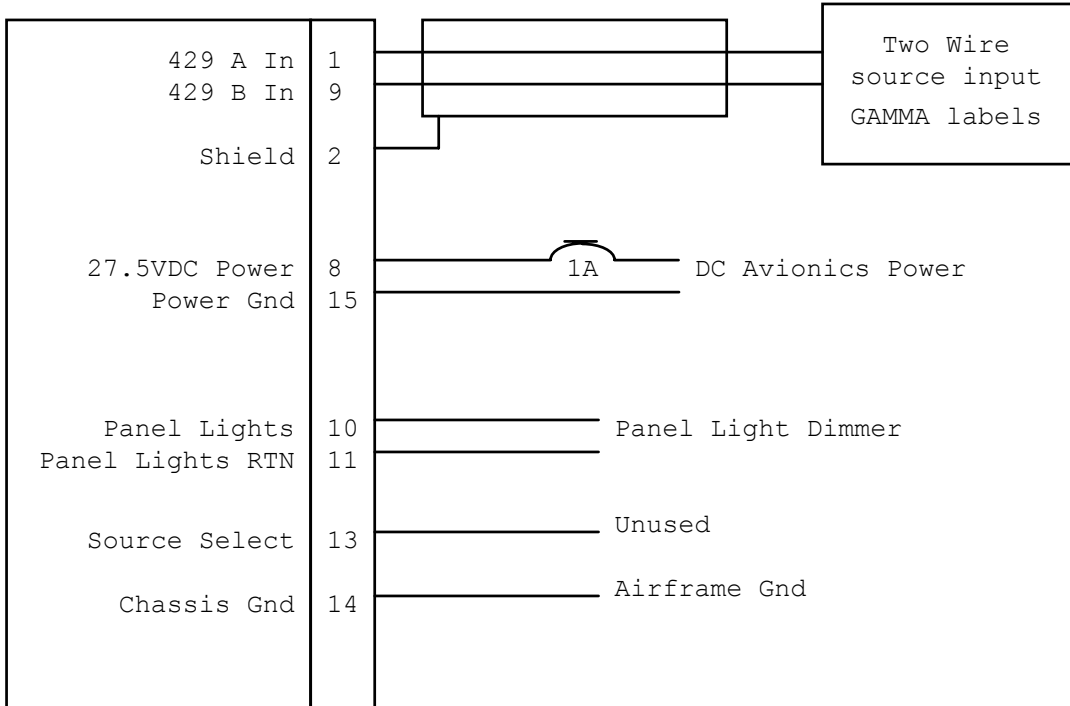

Connector: DA 15P (AMP P/N 745093-1)
 Mate: DA 15S (Standard 15 pin with male screw retainer)

IND-5000 P/N 50-5012-(XX) Pinout
 (illustration v-1)

v. Installation Specifications: Electrical (Continued)

2. Data Format

Input Labels being used must conform to the ARINC GAMMA 429 formatted standards. data format labels required for the proper operation of the IND-5000, P/N 50-5012-(XX) are as follows:

Selected Altitude Label 204

Update rate: function of ADC

Transmission rate: minimum of four times per second.

```

Bit   3 | 332 | 2222222221111111 | 1110 | 00000000
      2 | 109 | 8765432109876543 | 2109 | 87654321
      --Z-----Z-----Z-----Z-----Z-----Z-----
      P | SSM | 2' complement | 0000 | 00100001
      |   | fraction of PI Radians |   |
  
```

Where: SSM is 110 = positive & 111 = negative, else invalid, P is odd parity. (Ignored)

vi. Specifications

Specification	Characteristics
Compliance	TSO C113 - SAE AS 8034, RTCA DO160B A1/B/A/KPS/XXXXXX/A/A/A/A/A/A
Display	5 X 7 Dot Matrix LED
Characters	English Font Alphanumeric
Character Size	0.20" X 0.112"
Contrast	Minimum 5 in 10K fc Direct Sunlight
Luminous Intensity	Minimum 2400 fc / Typical 3400 fc
Viewing Angle	Lateral 130o / Vertical 90o
Viewing Distance	10" to 100" (29" Nominal)
Physical Dimensions:	
Height	1.52"
Length	5.90"
Width	3.25"
Weight	18ozs.
Temperature Range	Operational: -20oC to +70oC
Altitude	Controlled environment equivalent to 15000 ft. nonpressurized.
Power Requirements	28VDC at 0.5 Amps Peak, 0.275 Amps nominal.
Digital Input	ARINC 429, GAMMA: LABEL 204
Range	Altitude -304 to 19970m., +/- 10 meters
Accuracy	2.44 meters

vii. Major Components

1. Equipment Supplied

Model IND-5000 P/N 50-5012-(XX)		
Dim voltage	faceplate color	P/N
5V	Black	50-5012-01
5V	Gray	50-5012-11
28V	Black	50-5012-02
28V	Gray	50-5012-12

2. Equipment Required but not supplied

Standard 1/2 3ATI panel mounting clamp
Connector kit : Standard DA 15S connector with screw retainers

3. Interconnection

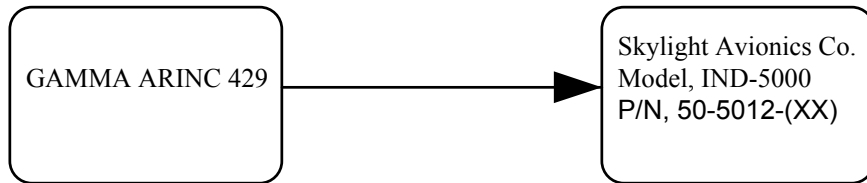

Interconnect Block Diagram
(Illustration vi-1)

(a) Connect to any 429 general purpose bus which outputs correct GAMMA labels. Interconnect varies by manufacturer. (See Section v.)

viii. Environmental Qualification Form

1. Nomenclature: IND-5000 Multi-function Digital Bus Reader
2. Part Number: 50-5012-(XX)
3. TSO Number: C113
4. Manufacture's Specification: None
5. Manufacturer: Skylight Avionics Company
 38629 6th Street East
 Palmdale, CA. 93550, USA

6. TEST:

Conditions	Section/ Paragraph	Test Conducted
Temperature & Altitude	4.0	Equipment tested
Low Temperature	4.5.1	to Category: A1
High Temperature	4.5.2/3	
Altitude Tests	4.6.1	
Decompression Tests	4.6.2	
Overpressure Tests	4.6.3	
Temperature Variation	5.0	Category B
Humidity	6.0	Category A
Shock	7.0	Equipment tested
Operational	7.2	per DO-160B
Crash Safety	7.3	Paragraph 7.1.1
Vibration	8.0	Equipment tested without shock mounts to Categories K,P and S (DO-160B, Table 8-1)
Explosion	9.0	"X" No tests required
Waterproofness	10.0	"X" No tests required
Fluids Susceptibility	11.0	"X" No tests required
Sand & Dust	12.0	"X" No tests required

viii. Environmental Qualification Form (continued)

Conditions	Section/ Paragraph	Test Conducted
Fungus	13.0	"X" No tests required
Salt Spray	14.0	"X" No tests required
Magnetic Effect	15.0	Tested as Class "A"
Power Input	16.0	Category A
Voltage Spike	17.0	Category A
Audio Frequency Conducted Susceptibility	18.0	Category A
Induced Signal Susceptibility	19.0	Category A
Radio Frequency	20.0	Category A
Radio Frequency Emission	21.0	Category A

Remarks:

Tests 4.0, 5.0, 6.0, 7.0 and 8.0 were conducted at:
A-BEC Environmental Testing Laboratories.

Tests 15.0, 16.0, 17.0, 18.0, 19.0, 20.0 and 21.0 were conducted at:
McPete Systems Company, EMC Science Center.

Compliance to FAR part 25 demonstrated by component parts and material analysis.